

Embedded electro-conductive yarn for shape sensing of soft robotic manipulators

Helge A Wurdemann, Sina Sareh, Ali Shafti, Yohan Noh, Angela Faragasso,
Damith S Chaturanga, Hongbin Liu, Shinichi Hirai, *IEEE Member*, Kaspar Althoefer, *IEEE Member*

Abstract — Flexible soft and stiffness-controllable surgical manipulators enhance the manoeuvrability of surgical tools during Minimally Invasive Surgery (MIS), as opposed to conventional rigid laparoscopic instruments. These flexible and soft robotic systems allow bending around organs, navigating through complex anatomical pathways inside the human body and interacting inherently safe with its soft environment. Shape sensing in such systems is a challenge and one essential requirement for precise position feedback control of soft robots. This paper builds on our previous work integrating multiple optical fibres into a soft manipulator to estimate the robot’s pose using light intensity modulation. Here, we present an enhanced version of our embedded bending/shape sensor based on electro-conductive yarn. The new system is miniaturised and able to measure bending behaviour as well as elongation. The integrated yarn material is helically wrapped around an elastic strap and protected inside a 1.5mm outer-diameter stretchable pipe. Three of these resulting stretch sensors are integrated in the periphery of a pneumatically actuated soft manipulator for direct measurement of the actuation chamber lengths. The capability of the sensing system in measuring the bending curvature and elongation of the arm is evaluated.

I. INTRODUCTION

The application of articulated instruments can enhance procedural steps during Minimally Invasive Surgery (MIS) compared to using rigid laparoscopic tools, e.g., when surgeons need to bend around soft tissue or bones inside the human body to reach targets. Adding flexibility to surgical instruments allows clinicians navigating within the complex anatomical environment and reduces the occasional necessity to reposition Trocar ports during a surgical intervention. Hence, the risk of damaging healthy tissue and/or organs is reduced. Examples of such flexible systems include the i-Snake system based on miniaturised universal joints [1], the HARP system based on concentric tubes [2], systems based on active cannulas [3], the STIFF-FLOP manipulator [4] with integrated sensors [5-7] and the inflatable robot [8-10]. These robotic systems are often made from mutually-tangent curved segments. When using these manipulators during operations, position feedback is achieved using visual tracking [11] or mounting electromagnetic trackers along the robot [12]. However, vision based tracking might be challenging due to

The work described in this paper is funded by the Seventh Framework Programme of the European Commission under grant agreement 287728 in the framework of EU project STIFF-FLOP.

Helge A Wurdemann Sina Sareh, Ali Shafti, Yohan Noh, Angela Faragasso, Hongbin Liu, and Kaspar Althoefer (email: k.althoefer@kcl.ac.uk) are with the Centre for Robotics Research, Department of Informatics, King’s College London, UK.

Damith S Chaturanga and Shinichi Hirai are with the Department of Robotics, Ritsumeikan University, Japan.

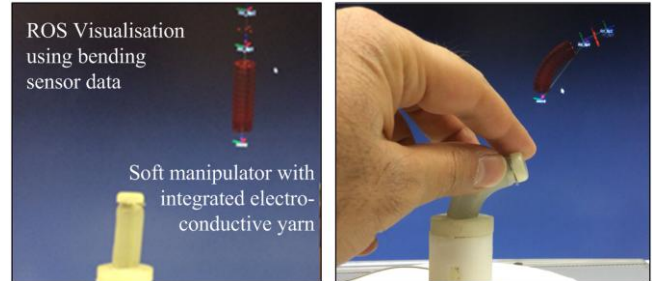

Figure 1. Shape sensor embedded in a soft manipulator of 12 mm diameter using electro-conductive yarn. The new bending sensor is calibrated and connected to RViz (the Robot Operating System Visualisation) to demonstrate the real-time performance of the sensor.

a partially restricted field of view whereas electromagnetic tracking systems might be subject to distortions caused by surrounding metallic equipment and to limited mobility with regards to the size of the generated magnetic field [13]. In order to precisely obtain position feedback and navigate towards a desired target inside the human body, an on-board shape sensing system can be beneficial.

An established approach to measure the bending curvature of flexible manipulators relies on strain/stretch measurements [14]. This method makes use of multiple tendons that are sliding at the same radial distance but different equally spaced angular positions around the central axis of a robotic arm. In response to a specific amount of bending deformation, the length of tendons inside the arm increases or decreases. The displacement of all tendons is measured and fed into a mathematical model to obtain the bending curvature of the arm [14]. Common methods of measuring the bending in such flexible structures include encoders [15], Fiber Bragg Grating (FBG) sensors [13], and light intensity modulation using optical fibres [16]. These methods require additional (costly) hardware such as encoders, interrogators, and light intensity sensors to convert the sensing signals to digital information. In addition, FBG systems are highly sensitive to strain conditions [13].

The work presented in this paper extends our previously published work where three pairs of optical fibres are integrated sliding within a silicone-based manipulator to estimate the pose of the tip [16]. Here, we embedded electro-conductive yarn with a diameter of ca. 0.7mm [17] in the periphery of a silicone-based soft manipulator. This material is made from a mixture of polyester and stainless steel fibres. The steel fibre is responsible for holding a certain level of conductivity along the length of the yarn, and hence changes its electrical resistance when elongating. The system has been miniaturised and is able to measure the

bending behaviour based on the implemented constant curvature model for continuum manipulators.

This paper explains the design and implementation of the low-cost and low-profile shape sensor based on electro-conductive yarn integrated inside a soft, pneumatically actuated manipulator with a diameter of 26mm (see Figure 4) and a miniaturised version without actuation and a diameter of 12mm (see Figure 1).

II. CHARACTERISATION AND INTEGRATION OF ELECTRO-CONDUCTIVE YARN

To determine the position and orientation of a continuum manipulator's tip, the arc parameters in the configuration space need to be known. These parameters containing bending and orientation angles and the radius of the arc can be calculated from the actuator space variables [14].

The objective of this paper aims to integrate stretchable, electro-conductive yarn into a soft robotic arm with pneumatic actuation and measure the length of the actuation chambers. Three actuation chambers are arranged in the periphery of the central axis of our manipulator with a radial displacement of 120° . Further, we describe how a set of three electro-conductive yarn strings has been integrated into a manipulator. In the following sections, the characterisation and implementation is presented as well as the mathematical model that is used to map between the actuation and configuration space.

A. Characterisation of electro-conductive yarn materials

A double coupling configuration of yarn material with an enhanced stretch sensing range [17] is used as shown in Figure 2. In this configuration, two threads of electro-conductive material are helically wrapped around an elastic strap in opposite direction. When a force is applied to both ends of a thread - resulting in an elongation of this thread - the yarn material shrinks laterally. The lateral shrinkage increases the density of the electro-conductive elements inside the thread reducing the overall electrical resistance of the yarn which can be measured. In order to characterise the electro-conductive yarn, a thread of 30mm length was analysed. A motorised linear rail was utilised to stretch the yarn. A voltage of 5V was applied to a voltage divider connecting a 100Ω resistance in series with the 30mm long thread which has a resistance of about 200Ω without any tension applied. When stretching the electro-conductive yarn up to 80mm which is equivalent to an elongation of 257%, the yarn does not tear and is still fully functional. However obtained sensor signals are affected by non-linear resistive behaviour and saturation for elongations above 150%.

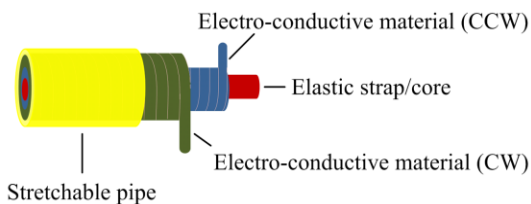

Figure 2. Structure of the electro-conductive yarn inserted into a stretchable pipe. A thread consists of an elastic strap and two layers of electro-conductive yarn material.

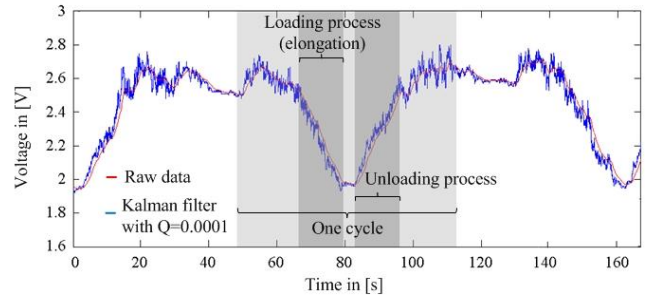

Figure 3. Measured raw voltage data (blue) and optimised voltage data by a Kalman filter (red) over a 30mm long electro-conductive yarn thread when stretching. The dark-grey area shows the linear range when the yarn is stretched up to 156%.

In Figure 3, one cycle of a loading and unloading process is recorded (see highlighted grey area). The graph shows measured voltage over time of the conducted experiment stretching the 30mm long piece of electro-conductive yarn by 156% to ca. 47mm (see highlighted dark-grey area). The raw voltage data is plotted in blue whereas the red curve shows the optimised data by a Kalman filter.

Due to a proportional relation between the resistance and the voltage, it can be seen that the yarn's resistance changes linearly during the loading and unloading process. The electro-conductive yarn can hence be used as a stretch sensor. Maximum hysteresis is calculated as 45% with an average hysteresis of 17%. Repeatability is about 83%.

B. Integration of the stretch sensor into a soft manipulator

As mentioned earlier, the electro-conductive yarn has been embedded into a soft manipulator which has been developed as part of EU FP7 project STIFF-FLOP. The manipulator is made of a silicone (Ecoflex 00-50) body with three reinforced pneumatic actuation chambers which are arranged in the periphery of the central axis with a radial displacement of 120° . The continuum robot of 30mm length and 26mm diameter can be bent and elongated and conforms with the constant curvature model. More details can be found in [18].

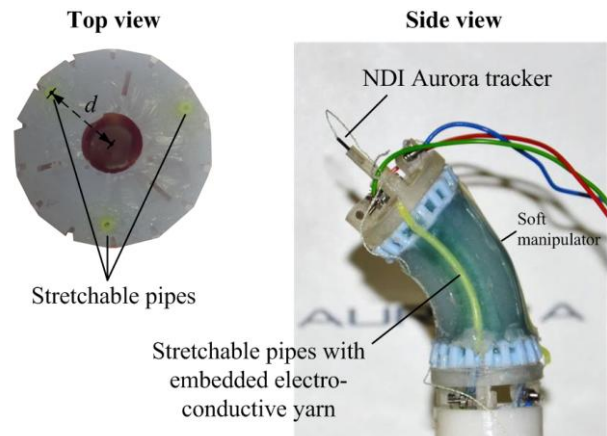

Figure 4. Top and side views of the integrated electro-conductive yarn bending sensors into a large-scale soft manipulator of 25mm diameter with pneumatic actuation. The Aurora magnetic tracking system will be used to evaluate the accuracy of the new bending sensor.

Figure 4 shows top and side views of the embedded electro-conductive yarn inside the STIFF-FLOP manipulator. A stretchable pipe is aligned with each pneumatic actuation chamber. The stretchable pipes have an outer diameter of 1.5mm and protect the stretching behaviour of the inserted electro-conductive yarn. Casting the yarn into silicone without this protection causes malfunction of the stretch sensor as the yarn is not able to laterally shrink during elongation. Now, the changing resistance of the embedded yarn can be mapped to the elongation of each actuation chamber.

C. Analytical model for mapping the actuation space variables to the arc parameters

As explained in the previous section, the shape sensing system consists of a set of three electro-conductive yarn threads with the resistances $[R_1(s_1), R_2(s_2), R_3(s_3)]$. As a linear function can be defined describing the relation between the resistance and the length of the yarn thread within the elongation interval $[0;156\%]$, it is possible to continuously calculate and update the length of the three threads $[s_1, s_2, s_3]$. These actuation space variables are now used to obtain the arc parameters as shown in Figure 5 and Equations 1-3 [16].

$$S = \frac{1}{3} \sum_{i=1}^3 (s_i) \quad (1)$$

$$\theta = \frac{S - s_1}{d \cos\left(\frac{\pi}{2} - \varphi\right)} \quad (2)$$

$$\varphi = \tan^{-1}\left(\frac{\sqrt{3}(s_2 + s_3 - 2s_1)}{3(s_2 - s_3)}\right) \quad (3)$$

S is the length of the central axis of the manipulator, r is the radius, $\theta = S/r$ is the bending angle and φ is the orientation. The parameter d describes the radial distance between the central axis of the manipulator and the stretchable pipes with the inserted yarn as marked in Figure 4 (top view). This distance is 12.5mm.

Having embedded three electro-conductive yarn threads inside the soft and flexible STIFF-FLOP manipulator and obtaining the lengths, we are able to describe the position and orientation of the robot's tip.

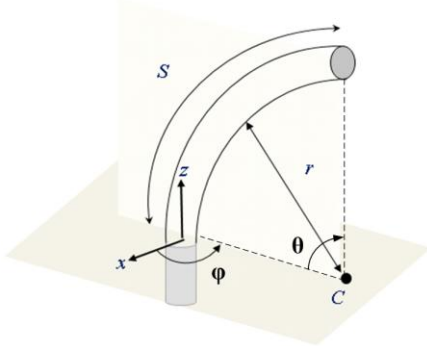

Figure 5. The pose of the tip of a continuum manipulator can be calculated by the arc parameters in the configuration space [8].

III. EXPERIMENTAL RESULTS

For validation, the system was integrated into ROS (Robot Operating System) using a RoNeX data acquisition board by the Shadow Robot Company. This allows us employing previously developed software for actuation and pose tracking and also visualising the sensing system in real-time.

A. Signal conditioning

In order to accurately detect changes in the conductive yarn's resistance and use it as an estimation of the soft manipulator's pose, a customised Wheatstone bridge circuit was used (see Figure 6). As mentioned in Section II, the length of the conductive yarn is about 30mm leading to a resistance of about 200Ω which changes about 100Ω when stretched by 156%. In order to get a sensing voltage within 0-4.4V analogue input range of our RoNeX board whilst maintaining low current passing through the robot arm, four static resistances ($3.3k\Omega$ each) were used to form the bridge. The conductive yarn was placed in series with one of them. In this manner the voltage picked up across the bridge is

$$V_{Bridge} = \left(0.5 - \frac{R + R_{Yarn}}{2R + R_{Yarn}}\right) V_{CC}. \quad (4)$$

The differential output of the bridge (V_{Bridge}) is fed into an instrumentation amplifier (IA). The Texas Instruments INA114 was selected for this task. The IA's input buffer eliminates the need for input matching and provides a large input impedance ensuring the transfer of voltage from the bridge to the amplifier. The high open loop gain and common mode rejection ratio ensure precision amplification. A single ended IA was used to facilitate integration with different types of data acquisition systems. The gain of the IA can be programmed using a resistance, R_G . As it is challenging to accurately match the resistance of the conductive yarn, differences in voltage ranges are compensated using the IA gain. Therefore, R_G is implemented using a potentiometer to make the circuit versatile and easily adaptable when using new sensing modules. A typical suitable starting value for R_G was $4.7k\Omega$.

The output of the IA with the correct potentiometer setting provides a suitable voltage range and variation. However, the signal is contaminated by noise. To fix this a two-pole passive low pass filter (LPF) was used. After studying the signal's Fast Fourier transformation (FFT) and performing initial experiments, the cut-off frequency of the LPF was set to about 3Hz.

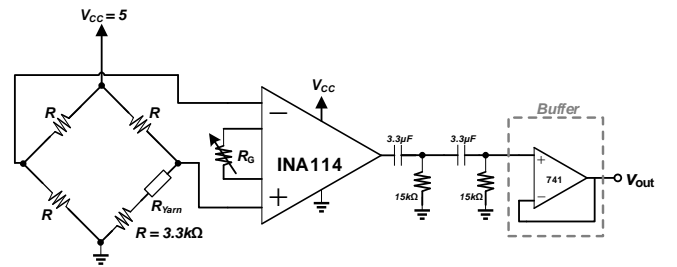

Figure 6. The interrogation circuit to detect changes in the yarn's resistance level.

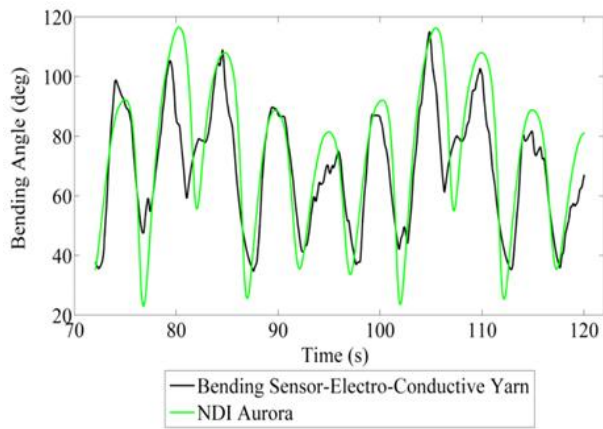

Figure 7. The bending angles obtained by the measurements of the electro-conductive yarn material (black) and by the NDI Aurora marker (green) are compared.

In order to connect this circuit to the RoNeX board, an additional buffer stage was required as its input impedance was not suitable for the sensing circuit's output. To overcome this problem, the LPF is effectively converted into an active LPF with a low output impedance. The final circuit schematic with component values and IC names is shown in Figure 6.

B. Initial validation experiments using the NDI Aurora tracking system

This section presents the experimental results indicating the capability of the yarn-based shape sensing system in comparison to obtained position data by the NDI Aurora system. The later magnetic tracking system is used as ground truth for benchmarking. Figure 4 shows the experimental setup including a STIFF-FLOP module with integrated pneumatic actuators, electro-conductive yarn stretch sensors and an NDI Aurora position sensor at the tip of the manipulator.

As an experimental protocol, the robotic manipulator was pneumatically actuated using ITV0030-3BS-Q pressure regulators, SMC Corporation, USA and a bench air compressor supplying the regulators with 5bar. Three control sine waves signals with a frequency of 0.1Hz and 120° mutual phase difference were applied to the pressure regulators.

The data from our embedded sensory system and the commercially available system were synchronously acquired. In Figure 7, we plotted the bending angle using data from our described shape sensing system and Equation 2 (black curve) and using the position data from the magnetic tracker at the tip assuming a constant curvature bending (green curve).

IV. CONCLUSIONS

In this paper, we presented the design and fabrication of a new shape sensing system based on electro-conductive yarn material. The coupling yarn material is characterised and embedded into a soft manipulator with pneumatic actuation. The sensor is low-cost, low-profile, suitable for integration

into miniature surgical instruments and modular implementation. Initial experimental comparison with a commercially available magnetic tracking system shows the potential of the embedded bending sensor system.

REFERENCES

- [1] G. J. Shang, D. Noonan, C. Payne, J. Clark, M. H. Sodergren, A. Darzi, G.-Z. Yang, "An Articulated Universal Joint Based Flexible Access Robot for Minimally Invasive Surgery", IEEE International Conference on Robotics and Automation, pp. 1147-1152, 2011.
- [2] A. Degani, H. Choset, B. Zubiate, T. Ota and M. Zenati, "Highly Articulated Robotic Probe for Minimally Invasive Surgery", IEEE Engineering in Medicine and Biology Society Conference, pp. 3273-3276, 2008.
- [3] R.J. Webster, A. M. Okamura, N. J. Cowan "Toward active cannulas: Miniature snake-like surgical robots", International Conference on Intelligent Robots and Systems, pp. 2857-2863, 2006.
- [4] M. Cianchetti, T. Ranzani, G. Gerboni, I. De Falco, C. Laschi, A. Menciassi "STIFF-FLOP Surgical Manipulator: mechanical design and experimental characterization of the single module", IEEE/RSJ International Conference on Intelligent Robots and Systems, 2013.
- [5] Y. Noh, E.L. Secco, S. Sareh, H.A. Wurdemann, H. Liu, K. Althoefer "A Continuum Body Force Sensor Designed for Flexible Surgical Robotic Devices" IEEE Engineering in Medicine and Biology Society, 2014.
- [6] S. Sareh, A. Jiang, A. Faragasso, T. Nanayakkara, P. Dasgupta, L.D. Seneviratne, H.A. Wurdemann, K. Althoefer "MR-Compatible Bio-Inspired Tactile Sensor Sleeve for Surgical Soft Manipulators" IEEE International Conference on Robotics and Automation, 2014.
- [7] Y. Noh, S. Sareh, J. Back, H.A. Wurdemann, T. Ranzani, E.L. Secco, A. Faragasso, H. Liu, K. Althoefer "Three-Axial Body Force Sensor for Flexible Manipulators" IEEE International Conference on Robotics and Automation, 2014.
- [8] F. Maghooa, A. Stilli, K. Althoefer, H.A. Wurdemann, "Tendon and pressure actuation for a bio-inspired manipulator based on an antagonistic principle" IEEE International Conference on Robotics and Automation, 2015.
- [9] H.A. Wurdemann, A. Stilli, K. Althoefer, "An antagonistic actuation technique for simultaneous stiffness and position control" Intl Conf on Intelligent Robotics and Applications, 2015.
- [10] Agostino Stilli, H.A. Wurdemann, K. Althoefer "Shrinkable, stiffness-controllable soft manipulator based on a bio-inspired antagonistic actuation principle" IEEE/RSJ International Conference on Intelligent Ro-bots and Systems, 2014.
- [11] J.M. Croom, D.C. Rucker, J.M. Romano, R.J. Webster. "Visual sensing of continuum robot shape using self-organizing maps", IEEE Int Conf on Robotics and Automation, pp. 4591 – 4596, 2010.
- [12] M. Mahvash, D.E. Dupont, "Stiffness Control of a Continuum Manipulator in Contact with a Soft Environment", IEEE/RSJ Int Conf on Intelligent Robots and Systems, pp.863-870, 2010.
- [13] S. Ryu, P. E. Dupont, "FBG-based Shape Sensing Tubes for Continuum Robots", IEEE Int Conf on Robotics and Automation, pp. 3531-3537, 2014.
- [14] R. J. Webster III, B. A. Jones, "Design and Kinematic Modeling of Constant Curvature Continuum Robots: A Review," International Journal of Robotics Research, vol. 29, no. 13, pp. 1661-1683, 2010.
- [15] D. Trivedi, C. Rahn, W. Kier, I. Walker, "Soft robotics: biological inspiration, state of the art, and future research", Appl. Bionics. Biomech. 5, pp. 99 – 117, 2008.
- [16] T.C. Searle, K. Althoefer, L.D. Seneviratne, H. Liu, "An optical curvature sensor for flexible manipulators", IEEE International Conference on Robotics and Automation, pp. 4415-4420, 2013.
- [17] V.A. Ho, D. Kondo, S. Okada, T. Araki, E. Fujita, M. Makikawa, S. Hirai, "Development of a Low-Profile Sensor Using Electro-conductive Yarns in Recognition of Slippage", IEEE/RSJ Int Conf on Intelligent Robots and Systems, pp. 1946-1953, 2011.
- [18] J. Frasc, J. Czarnowski, M. Macias, J. Glowka, M. Cianchetti, A. Menciassi, "New STIFF-FLOP module construction idea for improved actuation and sensing", IEEE Int Conf on Robotics and Automation, 2015.